

Knife Ring Flaker

Machine Sizes + Technical Data

05 | 2011



MAIER[®]
Technik für die Umwelt

DIEFFENBACHER GROUP

Knife Ring Flaker MRZ – Performance Data

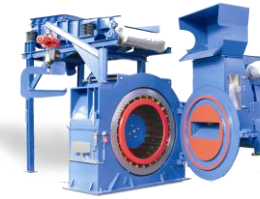
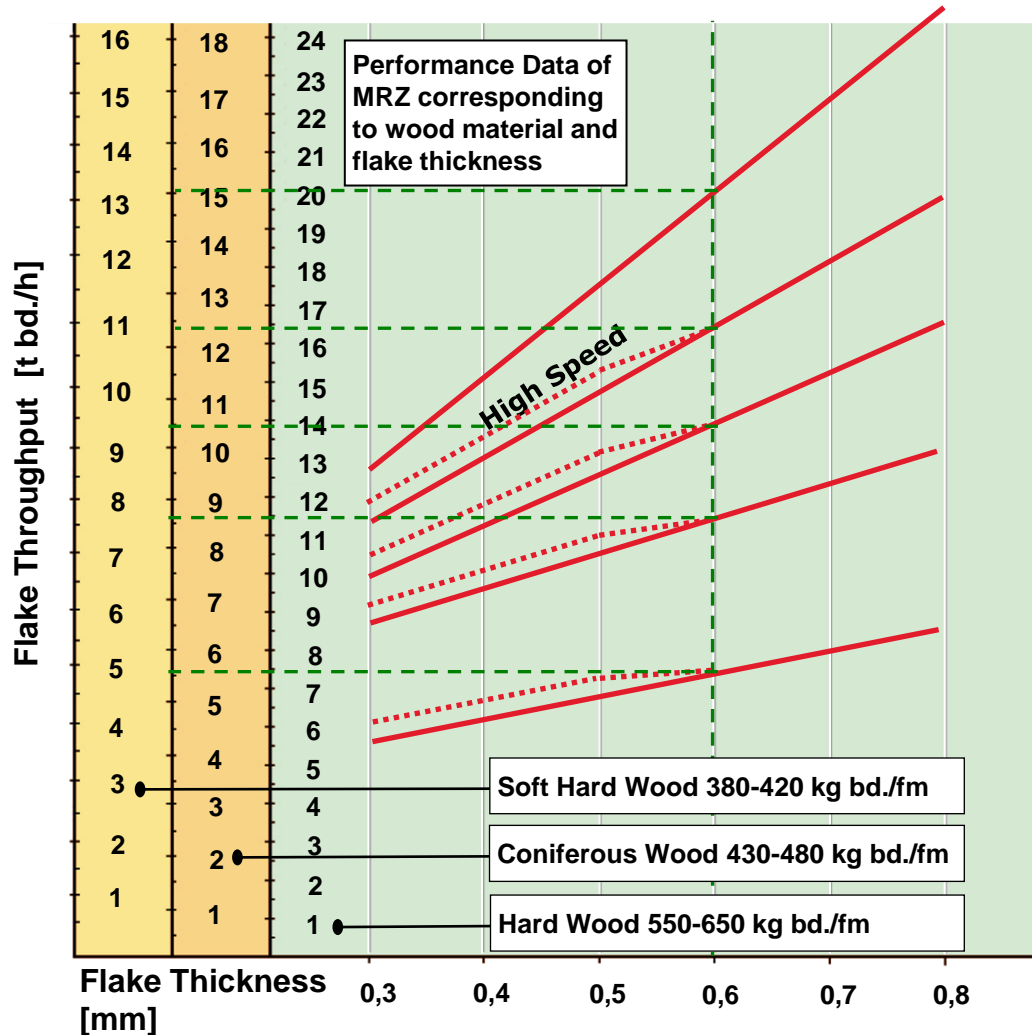

MRZ 1600 MR 72/76

12 - 18 t/h



MRZ 1500 MR 64

10 - 13 t/h



MRZ 1400 MR 60

5 - 11 t/h



MRZ 1200 MR 50

4 - 6 t/h

Knife Ring Flaker: Production



Production of Knife Ring Flaker

Knife Ring Flaker: Installation



Knife ring flaker in operation



Knife Ring Flaker: Installation Drawing

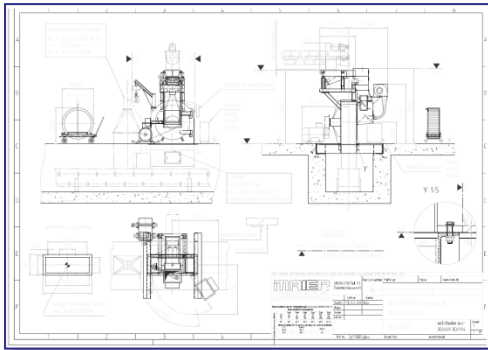

MRZ 1200

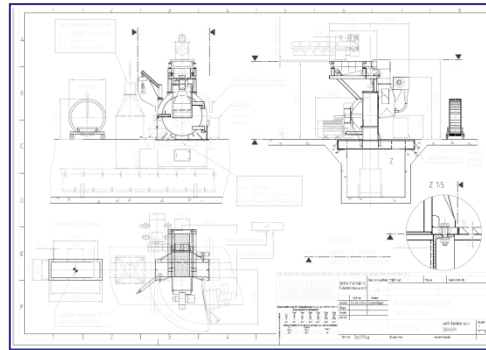

MRZ 1400

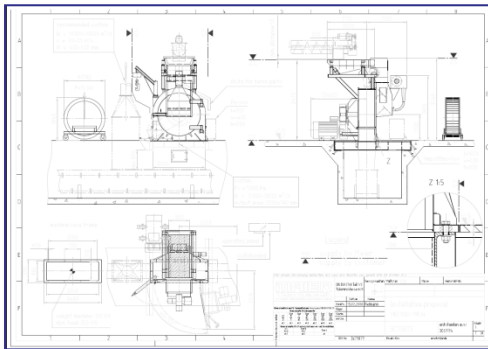

MRZ 1500

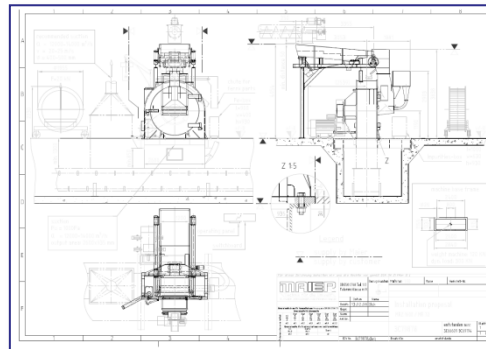

MRZ 1600